



HUNTER

XCI 286

INSTALLATION GUIDE FOR EXPOSED INTERIOR APPLICATIONS

COORDINATION

- Pre-construction meeting shall cover all decisions pertaining to design so that the Hunter Xci polyiso is properly installed.
- Review submittals, surface preparation, installation procedures, special details, sequence of construction, responsibilities, mock-up requirements, inspection, testing and repair procedures.
- Mock-up shall establish procedures and workmanship that must be followed during installation.
- Review adjacent construction materials such as windows, doors, ducts, and other penetrations for conformance to manufacturer's application instructions.
- Refer to project-specific contract documentation for components manufactured by others.

DELIVERY, STORAGE & HANDLING

- Protect polyiso during storage and installation.
- Store Hunter Xci polyiso insulation boards flat and protected from direct sunlight and extreme heat.
- Store Hunter Xci polyiso in a dry place protected from exposure to moisture. Material should be stored a minimum of 2" off the ground.
- Outdoor storage for extended periods of time requires covering with waterproof tarpaulins. Slitting the bundle packaging vertically down the center of the two short sides to prevent moisture accumulation within the package is recommended.

PROJECT/SITE CONDITIONS

- Do not adhesively apply Hunter Xci polyiso and associated materials in ambient and substrate temperatures below 25° F. Provide properly vented, supplementary heat during adhesive installation and drying period when temperatures less than 25° F prevail.
- Do not apply Hunter Xci polyiso and associated materials to damp or frozen surfaces. Hunter Xci polyiso should be applied over clean, dry substrates that provide sufficient support.
- Do not apply Hunter Xci polyiso for internal use in rain or when roof enclosure has not been completed.
- Protrusions and mortar droppings shall be removed from surfaces to facilitate fit and finish of Hunter Xci polyiso

APPLICATION

- Can be installed using adhesive attachment, mechanical attachment, clip or channel attachment, or through a combination of these methods.
- Should be installed continuously and secured appropriately to deliver its maximum impact on building energy efficiency.
- Typical interior exposed application will involve alignment of board joints for enhanced aesthetics.
- Should be installed vertically or horizontally and can be installed in multiple layers as needed to achieve maximum approved thickness.

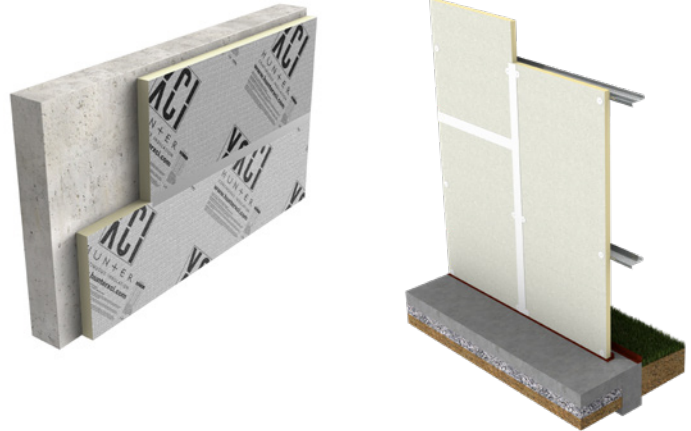

- Abut all Hunter Xci 286 boards joints tightly and ensure overall flush, level surface. Fill gaps greater than 1/16" between insulation boards with approved sealant, strike flush, and if desired cover with a seam tape for enhanced aesthetic appearance.
- Surface anomalies on either side of the product are inherent in the manufacturing process. No aesthetic warranty is provided.
- Pre-cut Hunter Xci 286 to fit openings and projections with table saw or knife using square to guide the cut.
- Consult local building codes and insurance authorities regarding special applications or details required when using Hunter Xci 286 as an exposed product.
- Insulation must be protected from open flame.
- Other acceptable methods of application not covered here may be incorporated during construction provided all applications follow proven and sound construction techniques.

REPAIRS AND MAINTENANCE

- Repair damaged Hunter Xci 286 by cutting out and replacing the damaged area.
- Small damaged areas can be filled with foam or caulking sealant.
- For repairs to mechanically fastened areas the Hunter Xci 286 should be brought to the nearest framing member so that proper fastening can be maintained.
- 15 mil reinforced foil facer is pressure washable.

ADHESIVE ATTACHMENT

- General construction adhesives may be used to secure board to various substrates where desired. Some commonly used adhesives for installing product for exposed interior use include:
 - Loctite PL-300 Foam Board Adhesive
 - Loctite PL-Premium Polyurethane Construction Adhesive
 - Chemlink WallSecure

- DAP Dyanagrip Foamboard Construction Adhesive
- BASF MasterWeld 420
- Before beginning installation, prepare all surfaces by cleaning any dust, dirt, or debris with appropriate materials, ensuring all surfaces are clean and dry.
- For interior application to concrete or CMU base walls, apply $\frac{3}{8}$ " thick by 3" diameter dabs of adhesive to back of polyiso board in 4 rows with a minimum of 7 dabs per row. Space adhesive dabs evenly across the length of the board at no more than 16" o.c. Space dabs in rows no more than 16" o.c. and no more than 3" from board ends and edges.
- For interior application to wood or metal framing, apply adhesive with a minimum $\frac{1}{4}$ " bead to framing member. Framing members should be placed no more than 24" o.c.
- With either application, immediately place insulation boards against the wall surface before adhesive "skins". If adhesive "skins", remove and apply fresh material.
- It is recommended that supplemental mechanical fasteners be used to further hold insulation board to substrate during adhesive cure in wall applications. For ceiling applications, supplemental mechanical fasteners are required.

MECHANICAL ATTACHMENT

- Each fastener going through the insulation is a potential thermal break. Reducing penetrations in the insulation improves the overall hygrothermal performance of the wall assembly.
- Use fastener with minimum 1.5" diameter plastic or metal plate/washer.
- Fastener penetration requirement will vary by type of fastener utilized and substrate. Follow fastener manufacturer's instructions on depth of penetration required into substrate being used.
- Drive fasteners so that the plastic or metal plate/washer is flush with insulation board surface. Do not countersink.

Concrete or CMU

- Common mechanical fasteners for interior exposed use in Concrete or CMU wall or ceiling applications include:
 - TRUFAST Walls Plasti-Grip PMF Anchors
 - Ramset I-F Fastening System for Concrete/CMU
 - Hilti Insulation Fastening System

Metal or wood framed walls

- Common mechanical fasteners for interior exposed use in framed wall or ceiling applications include:
 - TRUFAST Walls Plasti-Grip "ci" Prong Washers with Grip-Deck Screws (use appropriate screw for either wood or steel)
 - Ramset I-F Fastening System for Wood Framing or Steel Framing
 - Hilti Insulation Fastening System

Pre-engineered metal buildings

- Common mechanical fasteners for interior exposed use in pre-engineered metal building applications include:
 - TRUFAST Walls Plasti-Grip "ci" Prong Washers with Grip-Deck Self-Drilling Screws
 - Ramset I-F Fastening System for Steel
 - Hilti Insulation Fastening System

Fastening Patterns

4' x 8' Board - Wall

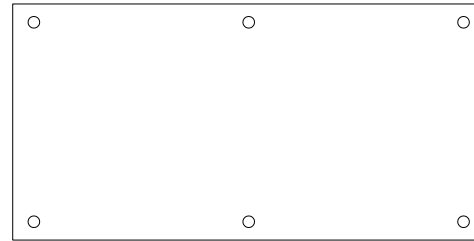

4' x 8' Board - Ceiling

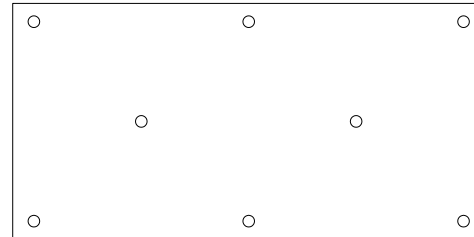

4' x 10' Board - Wall

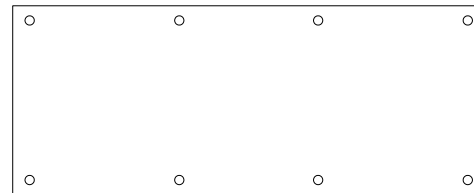

4' x 10' Board - Ceiling



Pre-Engineered Metal Building

4' x 10' Board - Wall/Ceiling

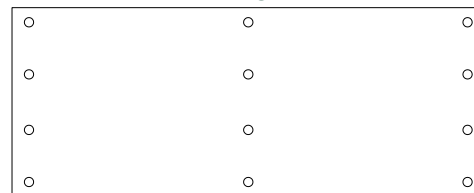

CLIP OR CHANNEL ATTACHMENT

- Independent accessory manufacturers have produced white PVC or vinyl trim pieces for use with interior exposed polyiso products for several years. Such trim pieces may help secure the foam board in place in various applications and provide variations on aesthetic appearance at board seams when used in conjunction with white-faced insulation materials.
- Manufacturers of such accessory trim pieces for interior application include:
 - Victory Bear Construction Products
 - Nudo Products
- Depending on manufacturer, options available may include:
 - H-channels which span the joints between boards.
 - Male/Female T-Channels which span joints between boards, consisting of a female locking channel that mounts to the base wall behind the foam board and a separate interlocking T-channel that will be exposed to the interior side of the assembly.
 - J-channels which envelop board terminations.

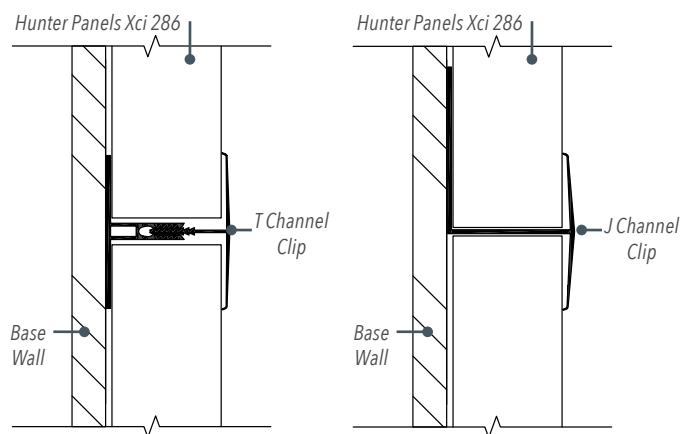

SEAM/JOINT TREATMENT OPTIONS

- Hunter Xci 286 has passed NFPA 286 interior exposed use testing in walls or ceilings with taped or untaped seams.
 - It is not required that seams be taped for interior application, seams may be left untaped.
- Board joints/seams are often taped or sealed in exposed interior applications. Any tape that will be left exposed to the interior should provide a flame spread index of <25 and smoke developed index of <450.
- A minimum 3" wide tape is recommended, with application centered on the board joint. Tapes should be rolled or squeegeed with firm pressure to ensure proper adhesion.
- When installing tape on a vertical joint, the tape should be applied so that any overlap occurs in a shingle fashion.
- Common tapes used for sealing seams of interior exposed applications include:
 - ECHOTape MT-A7770
 - 3M Venture White Aluminum Foil Tape 1558HT
 - ECHOTape MT-A7757 All Weather Aluminum Foil Tape (reflective)
 - Hunter Xci 286 White Foil Tape
- Follow tape manufacturer's instructions to ensure proper application. This includes recommendations surrounding surface preparation, applicable primer requirements, and application temperatures.
- Previously mentioned Clips/Channel Attachments can also provide seam/joint treatment options.